

**CONTINUOUS DROPPED CURB AT INTERSECTION CORNER**

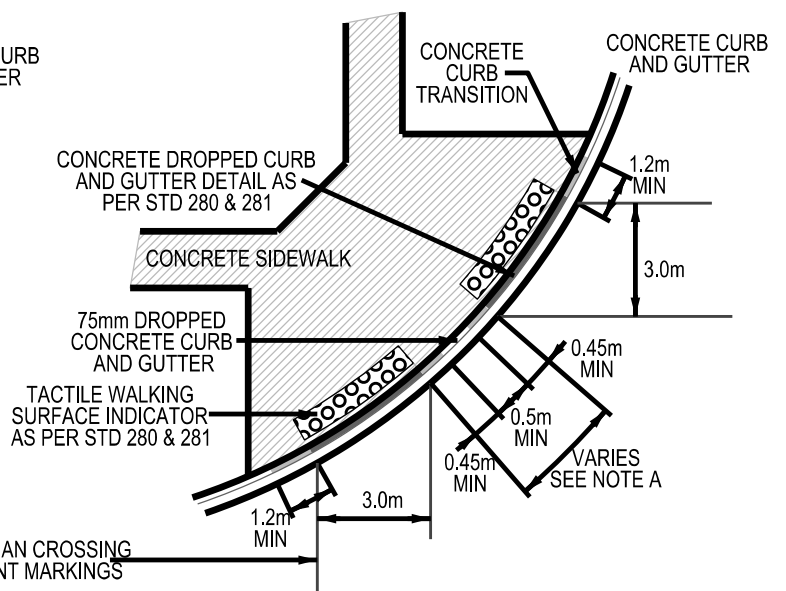

**TWO SEPARATED DROPPED CURBS AT INTERSECTION CORNER**

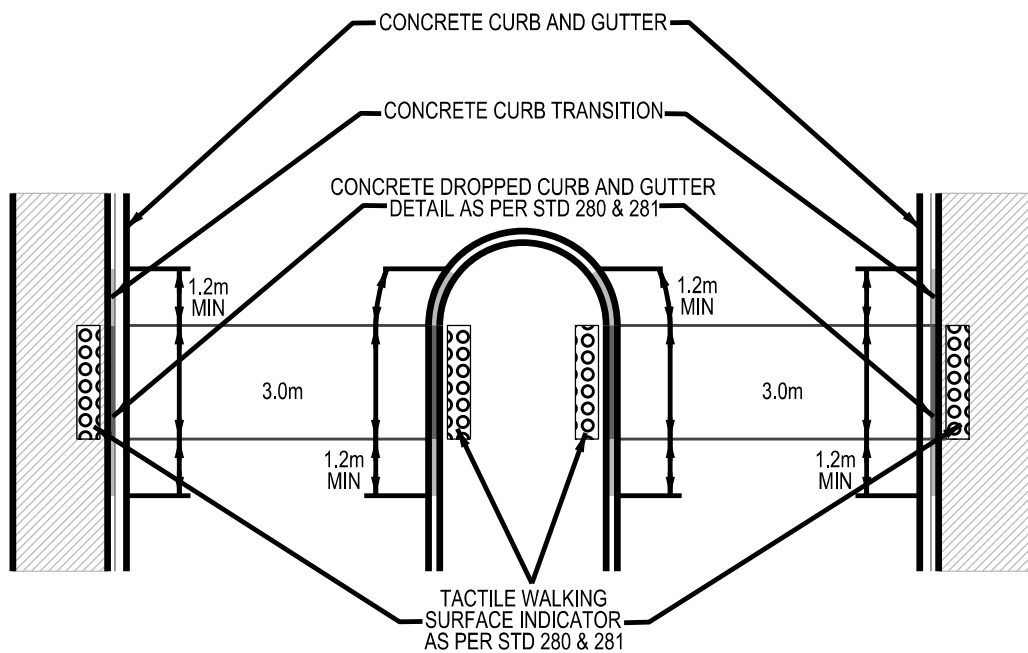

**DROPPED CURB AT PEDESTRIAN REFUGE ISLAND AND MID-BLOCK CROSSING WITH TWO STAGE PEDESTRIAN SIGNALS**

**NOTES**

- A. WHEN DISTANCE IS LESS THAN 1.4m USE CONTINUOUS DROPPED CURB AT INTERSECTION CORNER. WHEN DISTANCE IS GREATER THAN OR EQUAL TO 1.4m USE TWO SEPARATED DROPPED CURBS AT INTERSECTION CORNER.
1. DROPPED CURB TO BE PROVIDED FOR WIDTH OF ALL PEDESTRIAN CROSSINGS.
2. TACTILE WALKING SURFACE INDICATORS TO BE PROVIDED ONLY WITHIN WIDTH OF PEDESTRIAN CROSSING. TACTILE STRIPS SHALL NOT BE CONTINUOUS IF CROSSWALKS ARE SEPARATED.
3. TACTILE WALKING SURFACE INDICATORS ARE TO BE INSTALLED AT ALL PEDESTRIAN CROSSINGS IN CONJUNCTION WITH ALL ROAD AND SIDEWALK CONSTRUCTION AND RECONSTRUCTION AND RESURFACING PROJECTS.
4. EACH LOCATION IS SITE SPECIFIC AND CONSULTATION WITH THE CITY OF BRAMPTON SHALL BE REQUIRED FOR NON TYPICAL INTERSECTIONS AND PEDESTRIAN CROSSING LOCATIONS.
5. REFER TO STD. 284 FOR VARIOUS CONFIGURATIONS OF PEDESTRIAN CROSSINGS AT SIGNALIZED INTERSECTIONS AND STD. 283 FOR CONTROLLED NON SIGNALIZED INTERSECTIONS.

All dimensions in millimeters unless otherwise shown



**BRAMPTON**  
Flower City

APPROVED:  
JUL 24, 2015

LOCATION OF DROPPED CURBS AT CONTROLLED INTERSECTIONS

ORIGINAL:  
13/11/2014

REV. 1

**282**

N.T.S