

SECTION A-A

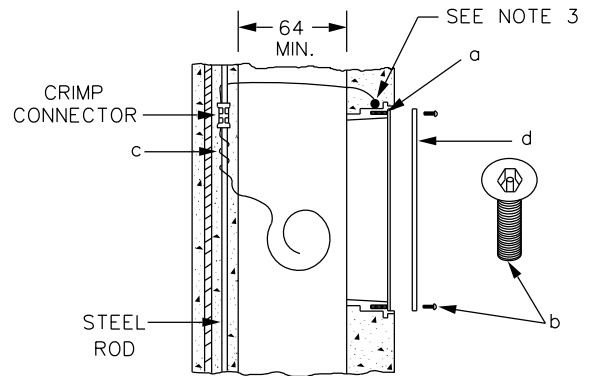

SECTION B-B

MATERIAL

- a. 1/4"-20x3/4" THREADED CORE.
- b. 1/4"-20x3/4" ALLEN KEY BUTTON PAN HEAD STAINLESS STEEL BOLT.
- c. GROUNDING LEAD - USE NO. 6 AWG MIN. STRANDED CU. WIRE, THREE TURNS, CRIMPED TO STEEL ROD. LEAD TO EXTEND 305mm OUTSIDE THE HANDHOLE.
- d. CAST METALLIC HANDHOLE FRAME AND COVER.

NOTE:

1. DIMENSIONS SHOWN ARE IN MILLIMETERS UNLESS OTHERWISE SPECIFIED.
2. POLE TO BE CONSTRUCTED AS PER CSA A14-00 OR LATEST REVISION
3. METALLIC HANDHOLE FRAME MUST BE ELECTRICALLY BONDED TO THE NO. 6 GROUND WIRE.
4. POLE SURFACE FINISH: "2SB" POLISHED SALUKIBROWN - USI
"CBP" CARPATHIAN BRONZE POLISHED - SKYCAST
"S90" POLISHED SALUKI BROWN - STRESSCRETE
5. TOP INSERT TO BE POSITIONED AT CENTER OF POLE.
6. CONTRACTOR TO APPLY ANTI-SEIZE TO HANDHOLE COVER BOLT



BRAMPTON
Flower City

**DECORATIVE
STREET LIGHT POLE**

C.S.A. CLASS 'B' 9.9m (32.5FT)
OCTAGONAL CONCRETE

STREET LIGHT DETAILS - 500

APPROVED:
MARCH
2017

ORIGINAL:
JUNE 2006

REV. 1

516

N.T.S